



MIC 6000

Eight Ramp/Soak Profiles

1/4 DIN Profile Controller

DESCRIPTION

The MIC 6000 is a 1/4 DIN, microprocessor based, single loop, profiling, process controller. It can function either as a basic process controller, utilizing manual setpoint changes or it can also execute any one of eight setpoint profiles; each profile can have six ramp and six soak segments.

Access to configuration parameters and setpoint may be restricted by using the instrument's security-access mode.

The MIC 6000 can provide single or dual control outputs and up to three event outputs. The unit can include two 4-20mA current outputs which can be used for control or optional process value retransmission.

APPLICATIONS:

Programmable profile device stores and implements temperature control sequences including ramp/soak profiles.

INDUSTRIES

- Industrial and lab ovens/furnaces, plastics and thermal forming
- Form/fill and seal
- Packaging applications
- And any others where low costs, smaller size and unmatched connectivity are critical requirements.

FEATURES/BENEFITS

- 4-digit, 0.56" high, LED display
- 1/4 DIN panel mount
- Input options for thermocouple, RTD, DC linear mA/V/mV
- Sensor fault detection
- Up to 5 outputs; relay, 4-20mA, SSR driver
- Process, deviation, deviation band alarms
- Eight Ramp/Soak profiles
- Optional RS-485 serial communications
- Program security

SPECIFICATIONS*

STANDARD FEATURES

- Up to 5 outputs via relay, 4-20 mA current or SSR driver
- Alarm or Event output
- Available inputs for T/C, RTD, Voltage or Current
- Sensor fault detection
- Optional remote Run/Hold, Position Proportioning or RS-485 Communications

ENVIRONMENTAL CHARACTERISTICS

- Operating Temperature:** 0 to 55°C, 32 to 131°F
- Storage Temperature:** -40 to 65°C, -40 to 149°F
- Humidity:** 0 to 90% RH, non condensing
- Vibration:** 0.5 to 100Hz at 0.5g

ELECTRICAL

- Line Voltage:** 115/230VAC +/- 10% 50/60 Hz
- Power Consumption:** 15VA maximum
- Transmitter Power Supply:** Provides up to 40mA @ 24 VDC.

INPUTS

- Thermocouple types:** J, K, T, R, S, E, B, N, and C.
- RTD:** 100 ohm platinum (.00385 Ohm/Ohm/C)
- Volts:** 0 to 5VDC, 1 to 5 VDC
- Millivolts:** 0 to 25mVDC, 0 to 50mVDC, 10 to 50mVDC
- Milliamps:** 0 to 20 or 4 to 20mADC, accommodated via the addition of a shunt resistor
- Remote Run/Hold:** Dry contact-closure
- Sensor Fault Detection:** Displays Hi or Lo for thermocouple or RTD inputs (10% above or below range) and sensor break, SnSr. On/Off outputs go off, proportional outputs go to 0%. Sensor fault detection is not functional for 0 to 5VDC or 0 to 20mADC.

OUTPUTS

- Relay:** SPST
115VAC: 5.0 A Resistive; 1/8HP or 250VA
230VAC: 2.5 A Resistive; 1/8HP or 250VA
- SSR Driver:** Open collector output Short circuit protected at 100mA maximum
Provides 4VDC at 20mA or 3VDC at 40mA
- Current Output:** 0-20 or 4-20 mADC into 650 ohms maximum

DISPLAY

- Digital Display:** Four 7 segment LEDs each 0.56 inches. Individual LED indicators for Setpoint, Out 1, Out 2, Manual, Alarm, Degrees F, Degrees C, or Engineering Units, and minus sign for negative values, Segment 1 – 6, ramp and soak

ALARM ADJUSTMENT

- Process Alarm:** -9999 to 9999 units
- Deviation Alarm:** -3000 to 3000 units
- Deviation Band Alarm:** 1 to 3000 units

CONTROL ADJUSTMENTS

- On/Off Hysteresis:** 0 to 300 units
- Proportional Band:** 1 to 3000 units
- Manual Reset:** -1500 to 1500 units
- Auto Reset:** 0.0 to 100.0 repeats/minute
- Rate:** 0.0 to 10.0 minutes
- Cycle Time:** 1 to 240 seconds
- Position Prop. Sensitivity:** 0.0 to 50.0%
- First Output Position:** -1000 to 1000 units
- Spread:** -1000 to 1000 units (Second Output Position)
- Profile Time Base:**
Selectable for ramp time and soak time as:
HHH.T (hrs. & tenths)
HH.MM (hrs. & min.)
MM.SS (min. & sec.)
Selectable for ramp rate (EO option only) as:
XXX.X (units per hour)
XXX.X (units per minute)

PERFORMANCE

- Measurement Error Limit:**
 - Type J, K, T, E, N, C thermocouples and RTD +/- 0.25% of reading plus 1 degree at 25°C
 - Type R, S, B thermocouple +/- 0.25% of span at 25°C
 - mVDC, mADC and VDC +/- 0.25% of span, plus 1 least-significant-digit at 25°C
- Ambient Temperature Error:** 0.01% of span per degree C deviation from 25°C
- Scan Rate:** 1 scan per second (3 scans per second available on EA option)
- Display Resolution:** T/C & RTD: 0.1 or 1 degree mV & VDC: 0.001, 0.01, 0.1, or 1.0
- Auto Reset Windup Inhibit:** Auto reset is disabled when the process is outside of the proportional band
- Cold Junction Compensation:** Self compensation for ambient temperature. All calibration values are stored in memory.
- Noise Rejection:** Normal mode, 85dB minimum @ 60Hz or greater. Common mode, 90dB minimum ±8 VDC maximum peak for RTD input, 115VAC maximum for other inputs.

PHYSICAL DIMENSIONS

- Dimensions:** 1/4 DIN front panel, 5.8" deep
- Weight:** 3 pounds maximum

COMMUNICATIONS

- Type:** RS-485 serial communication port
- Protocol:** Partlow ASCII

RATINGS/AGENCY APPROVALS

- UL & cUL recognized (E67237), CSA (LR39885)

WARRANTY

- 3 years
- Made in USA

* Specifications are for base models with standard features only unless otherwise noted. Specifications subject to change without notice in accordance with our DBS policy of continuous improvement. All product and brand names are trademarks of their respective owners. All rights reserved.

Partlow™ brand and MIC 6000™ are trademarks of Danaher Industrial Controls Group. All rights reserved.

© 2005 DICG Corp.

Partlow Brand MIC 6000 Data Sheet (7/05)

1/4 DIN Profile Controller

MODELS

Code 1: Model #	Code 2: Input	Code 3: Output Group 1 Control Group 1 and/or Event	Code 4: Output Group 2 Control Output 2 or Event	Code 5: Output Group 3 Alarm or Event	Code 6: Remote	Code 7: Voltage	Code 8: Option Suffix
6	<input type="checkbox"/>	<input type="checkbox"/>	<input type="checkbox"/>	<input type="checkbox"/>	<input type="checkbox"/>	<input type="checkbox"/>	<input type="checkbox"/>
1/4 DIN Profile Controller	1 T/C or mV 2 Volts/mA 3 RTD 4 All Inputs	1 Relay 2 SSR Driver 3 4-20mA and Relay 4 4-20mA and SSR Driver	0 None 1 Relay 2 SSR Driver 3 4-20mA 4 4-20mA and Relay 5 4-20mA and SSR Driver	0 None 1 Relay 2 SSR Driver	0 None 1 Position Proportioning* 2 Remote Run/Hold 3 RS-485 Standard Com.** 4 RS-485 Standard Com.*** 5 RS-485 Total Access Com.** 6 RS-485 Total Access Com.***	1 115 VAC Input & Relays 2 230 VAC Input & Relays 3 115 VAC Input & 230 VAC Relays	(Blank) None BA Remote Keypad EO Extended Feature Software XP 24VDC Transmitter Power Supply XA 24VDC Power Supply†† AI 40 Profiles†

DIMENSIONS - 1/4 DIN

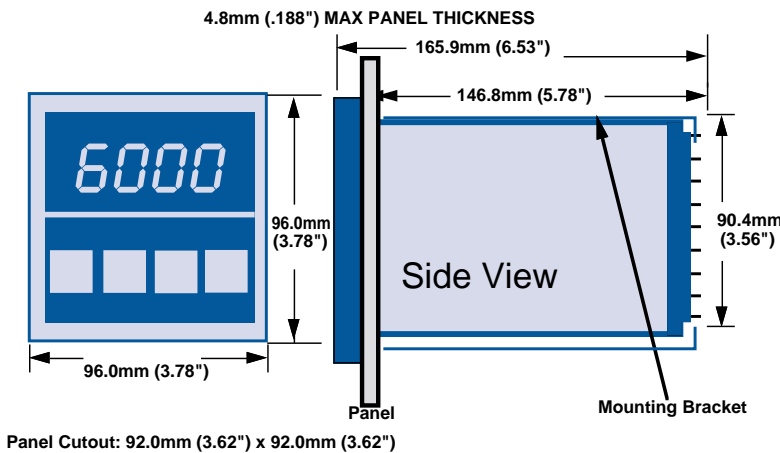

- * Limited to Model 6X11X1X or 6X22X1X.
- ** Output Group 2 cannot be 3, 4, or 5.
- *** Output Group 3 cannot be 1 or 2.
- † If com is required, only Total Access Com. is available.
- †† ALARM not available when XA suffix is ordered.

Note: RS-485 Total Access Com. includes Option EO. Option E